

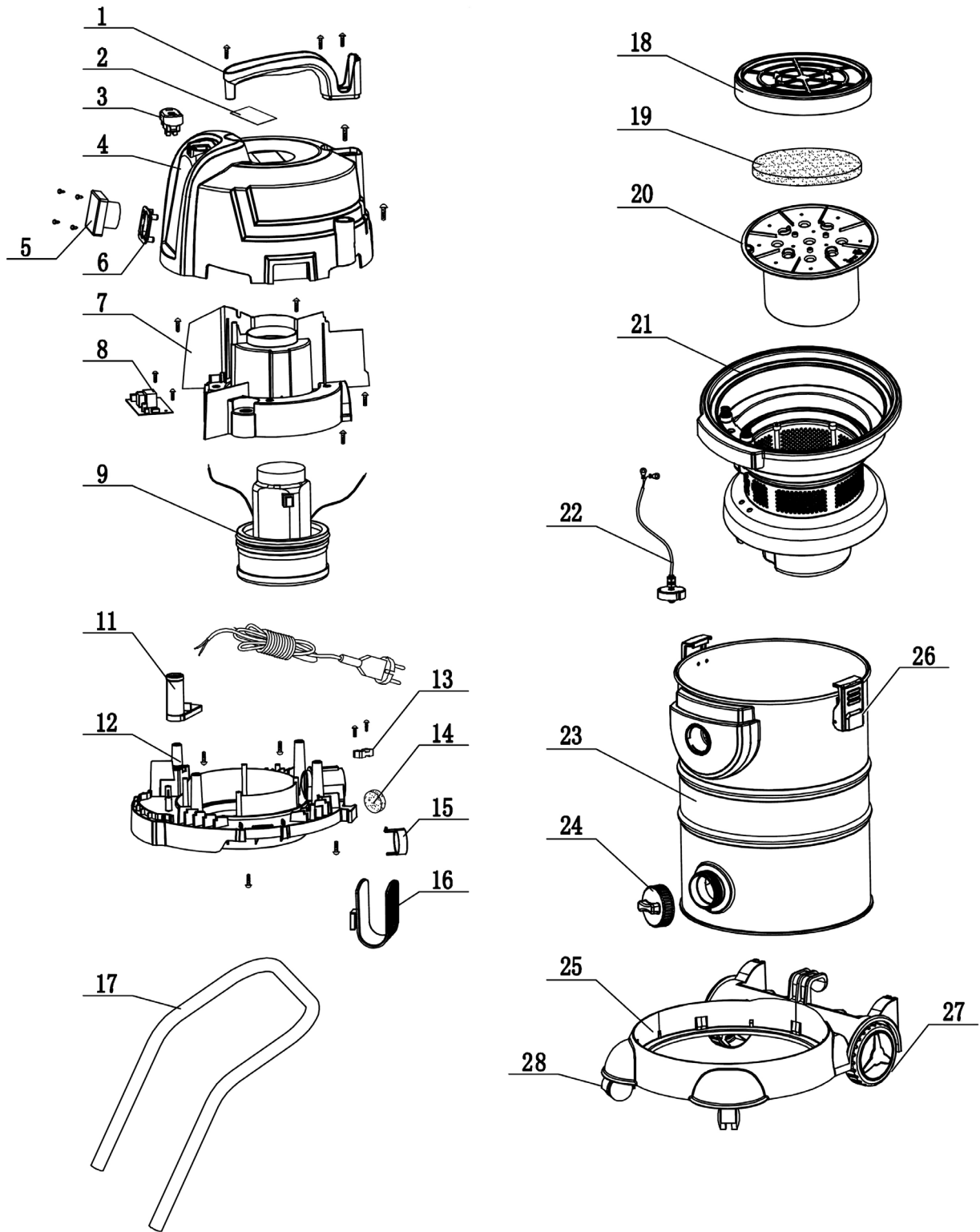

Parts Information:  
30L Industrial Cyclone Vacuum Cleaner  
Wet & Dry 1200W/230V  
Model No: PC300BL



**NOTE:** It is our policy to continually improve products and as such we reserve the right to alter data, specifications and component parts without prior notice. There may be alternative versions of this product, please contact us should you require this information.

**IMPORTANT:** No liability is accepted for incorrect use of product. Spare parts must be fitted by a competent person

**WARRANTY:** Guarantee is 12 months from purchase date, proof of which will be required for any claim.



Parts Information:  
**30L Industrial Cyclone Vacuum Cleaner**  
**Wet & Dry 1200W/230V**  
**Model No: PC300BL**

Item	Part No.	Description
1	PC300BL.01	Top Handle
2	PC300BL.02	Rating Label
3	PC300BL.03	Switch
4	PC300BL.04	Top Cover
5	PC300BL.05	Socket Assembly
6	PC300BL.06	Socket Base
7	PC300BL.07	Motor Cover
8	PC300BL.08	PCB, Control Board, 100 x 55mm
9	PC300BL.09	Motor Assembly
11	PC300BL.11	Air Intake Tube
12	PC300BL.12	Middle Cover
13	PC300BL.13	Cable Grip
14	PC300BL.14	Outlet Filter
15	PC300BL.15	Outlet Filter Cover
16	PC300BL.16	Hose Bracket
17	PC300BL.17	Handle
18	PC300BL.18	Intake Filter Cover Assembly
19	PC300BL.19	Air Inlet Filter
20	PC300BL.20	Cyclone Assembly

Item	Part No.	Description
21	PC300BL.21	Cyclone Cover Assembly
22	PC300BL.22	Water Indicator
23	PC300BL.23	Tank Assembly
24	PC300BL.24	Water Drainage Assembly
25	PC300BL.25	Base Assembly
26	PC300BL.26	Bin Clip
27	PC300BL.27	Wheel, Rear Fixed, Plastic (Ø103 x 30 x Ø18mm Bore)
28	PC300BL.28	Wheel, Swivel Castor, Single Bolt (Ø47 x 36 x 67mm)
--	PC300BL.29	Suction Tube, Metal (Not Shown)
--	PC300BL.30	Crevice Tool (Not Shown)
--	PC300BL.31	Round Brush (Not Shown)
--	PC300BL.32	Floor Nozzle (Not Shown)
--	PC300BL.33	Hose Assembly (Not Shown)
--	PC300BLFF10	Foam Filter for PC300BL (Pack of 10) - <b>Please see Catalogue</b>
--	PC300BLPF	Panel Filter for PC300BL - <b>Please see Catalogue</b>

**NOTE:** It is our policy to continually improve products and as such we reserve the right to alter data, specifications and component parts without prior notice. There may be alternative versions of this product, please contact us should you require this information.

**IMPORTANT:** No liability is accepted for incorrect use of product. Spare parts must be fitted by a competent person

**WARRANTY:** Guarantee is 12 months from purchase date, proof of which will be required for any claim.

**Jack Sealey Ltd t/a Sealey Group, Kempson Way, Suffolk Business Park, Bury St Edmunds, Suffolk, IP32 7AR UK**

**Jack Sealey (EU) Ltd t/a Sealey Group, Farney Street, Carrickmacross, Co. Monaghan, A81 PK68 Ireland**

**Tel: 01284 757500 - Email: sales@sealey.co.uk - Web: www.sealey.co.uk**